

Full Length Article

## Dual Axis Solar Tracker Without Microcontroller

S. Mayuri<sup>1</sup>, S. Kavya Sri<sup>2</sup>, K. Vaishnavi<sup>3</sup>, D. Godhavar<sup>4</sup>

<sup>1</sup>Assistant Professor; Department Of Electrical And Electronics Engineering, Bhoj Reddy Engineering College For Women, Hyderabad, India.

<sup>2,3,4</sup>B.Tech Students, Department Of Electrical And Electronics Engineering, Bhoj Reddy Engineering College For Women, Hyderabad, India.

Mail Id; [kursalivaishnavi3@gmail.com](mailto:kursalivaishnavi3@gmail.com)<sup>3</sup>

Accepted 26-03-2026

*Author(s) Retains the Copyrights of This Article*

### ABSTRACT

Solar energy is one of the most widely used renewable energy sources, but its efficiency depends on the alignment of the solar panel with the sun. In fixed panels, maximum energy is received only for a short duration. To overcome this limitation, this project presents a dual axis solar tracker that automatically adjusts the position of the solar panel to follow the sun's movement in both directions. The system is designed without using a microcontroller, making it simple, cost-effective and easy to implement. It uses multiple Light Dependent Resistor (LDR) sensor modules placed around the setup to detect the intensity and direction of sunlight. When light falls unevenly on these sensors, a difference in output is generated, which is used to control the movement of the panel. An L298N motor driver module is used to control two DC motors. One motor is used for horizontal rotation (left-right movement) and the other is used for vertical tilt (up-down movement) of the solar panel. Based on the signals from the LDR sensors, the motors rotate the panel until it reaches the position of maximum light intensity. The system also includes a power supply unit consisting of a rectifier, filter capacitor and voltage regulator to provide a stable DC supply. A battery is used to power the circuit and LED indicators are used to show the working condition of the system and sensor outputs. The solar panel mounted on a mechanical structure is capable of adjusting its position smoothly using the motor arrangement. As the panel continuously tracks the sun, it receives more sunlight compared to a fixed panel, thereby improving overall efficiency. This project demonstrates a practical and effective way of increasing solar energy utilization using simple components without any programming. Additionally, the system is easy to build, understand and maintain, making it suitable for student projects and educational purposes. With further improvements, this model can be developed into a real-time solar tracking system for better energy generation in practical applications.

### Keywords:

Dual Axis Solar Tracker, Solar Energy, Light Dependent Resistor (LDR), L298N Motor Driver, DC Motors, Sun Tracking System, Renewable Energy, Automatic Panel Alignment, Energy Efficiency, Microcontroller-Free Design, Solar Panel Optimization, Analog Control System

### 1. INTRODUCTION

Solar energy is one of the most important renewable energy sources used today for power generation. It is clean, freely available, and environmentally friendly. However, the efficiency of a solar panel mainly depends on how well it is positioned with respect to the sun. In most cases, solar panels are fixed in one direction, due to which they receive maximum sunlight only during a particular time of the day, leading to reduced overall energy output.

To improve the efficiency of solar panels, solar tracking systems are used. These systems adjust the position of the panel so that it always faces the sun. A dual axis solar tracker is more effective than a single axis tracker because it can move in both horizontal (east-west) and vertical (north-south) directions, allowing the panel to capture maximum sunlight throughout the day. In this project, a dual axis solar tracker is designed and implemented

without using a microcontroller. Instead of programming, the system uses Light Dependent Resistor (LDR) sensor modules to detect the intensity and direction of sunlight. These sensors are placed around the panel to sense variations in light. When there is a difference in light intensity, the system responds by adjusting the panel position. The movement of the solar panel is achieved using two DC motors. One motor controls the horizontal rotation, while the other controls the vertical tilt of the panel. An L298N motor driver module is used to control the motors based on the signals received from the LDR sensors. The system also includes a power supply circuit with a rectifier, capacitor and voltage regulator to provide a stable DC supply, along with a battery for operation.

This project focuses on using simple and easily available components to build an effective solar tracking system. By avoiding the use of a

microcontroller, the design becomes less complex and easier to understand. The model demonstrates how solar energy can be utilized more efficiently with basic electronics and mechanical arrangement.

#### LITERATURE SURVEY

Reza Sadeghi *et al.* (2025) present a comprehensive review and comparative analysis of solar tracking systems, focusing on fixed, single-axis and dual-axis solar trackers. The study evaluates recent tracking configurations, sensing techniques and control approaches used in photovoltaic systems. The authors report that dual-axis tracking systems achieve significantly higher energy output compared to fixed installations by maintaining optimal panel orientation throughout the day. This review highlights recent advancements and performance improvements in solar tracking technology, providing a strong foundation for further research in this field [1].

Priyam Bhattacharya (2025) presents a dual-axis solar tracking system designed to continuously align a photovoltaic panel with the sun's trajectory throughout the day. The system enables movement along both azimuth and elevation axes to maximize solar exposure. Performance analysis confirms improved energy capture compared to conventional fixed-panel systems. The study emphasizes the role of precise tracking mechanisms and mechanical design in achieving higher photovoltaic efficiency [2].

The Dual Axis Solar Tracking System presented in the E3S Web of Conferences (2025) describes an autonomous tracking mechanism capable of dynamically adjusting the solar panel orientation in response to the sun's movement. The proposed system improves solar energy conversion by ensuring continuous perpendicular alignment with incoming sunlight. Experimental observations confirm that the dual-axis configuration significantly enhances power output and overall system efficiency, making it suitable for modern renewable energy applications [3].

Prajwal D. *et al.* (2024) present the design and implementation of a dual-axis solar tracker aimed at improving photovoltaic efficiency by tracking the sun in both horizontal and vertical directions. The system utilizes light sensors to detect solar position and actuates DC motors to adjust the panel orientation accordingly. Experimental results demonstrate a noticeable increase in power generation when compared to stationary solar panels, confirming the effectiveness of dual-axis tracking in enhancing solar energy utilization [4].

S. S. Jaafar *et al.* (2024) present a comparative performance evaluation of dual-axis solar tracking systems, analyzing their efficiency against fixed and single-axis configurations under real operating conditions. The study measures solar irradiance, tracking accuracy and power output. The results

indicate that dual-axis trackers achieve superior performance, with energy gains of up to 40–45% over fixed panels, validating the importance of continuous solar alignment for maximum energy harvesting [5].

#### OBJECTIVE

The main objective of this project is to design and develop a dual axis solar tracker that can automatically follow the movement of the sun in both horizontal and vertical directions to maximize solar energy generation. The system aims to improve the efficiency of a solar panel by ensuring it always receives maximum sunlight throughout the day. Another objective is to implement the tracking mechanism without using a microcontroller, making the system simple, cost-effective and easy to understand. The project also focuses on using LDR sensors to detect light intensity and control DC motors through an L298N motor driver module for panel movement.

#### PROJECT DESCRIPTION

The Dual Axis Solar Tracker without Microcontroller is a system designed to automatically adjust the position of a solar panel so that it receives maximum sunlight throughout the day. The system tracks the movement of the sun in two directions (horizontal and vertical) to improve the efficiency of solar power generation. Unlike advanced tracking systems that use microcontrollers, this project uses simple electronic components such as LDR sensors, an L298N motor driver, DC motors, battery and power supply to control the movement of the solar panel. In this system, the solar panel is the main component that converts sunlight into electrical energy. The energy generated by the solar panel is stored in a battery so that it can be used later when sunlight is not available. The power supply unit regulates and provides the required voltage to the electronic components and motor driver circuit for proper operation. The project uses four Light Dependent Resistors (LDR1, LDR2, LDR3 and LDR4) to detect the direction and intensity of sunlight. LDRs are sensors whose resistance changes depending on the amount of light falling on them. These sensors are placed at different positions around the solar panel. When sunlight falls equally on all the LDRs, the solar panel remains in a fixed position. If the sunlight becomes stronger on one side, the resistance of that LDR changes and the system detects the difference. The signals from the LDR sensors are given to the L298N motor driver module. The L298N driver acts as a control unit that processes the signals from the sensors and drives the motors accordingly. It controls the direction and movement of the DC motors, allowing the solar panel to rotate in two axes. Two DC motors are used in the system. One motor rotates the solar panel in the east–west direction to follow the sun from morning to evening. The second motor adjusts the

panel in the north–south direction to maintain the correct tilt angle of the panel. This dual-axis movement helps the panel to always face the sun directly. When the LDR sensors detect that sunlight is stronger in a particular direction, the L298N motor driver activates the corresponding DC motor. The motor then rotates the solar panel toward the direction of maximum sunlight. Once the light intensity becomes equal on the sensors, the motor stops automatically.

## HISTORY

The use of solar energy began many years ago when scientists started exploring renewable sources of energy. In the early stages, solar panels were mainly used for scientific experiments and space applications. During the 1950s, solar panels were first used in satellites to generate electricity from sunlight. These panels were usually kept in a fixed position, which limited the amount of sunlight they could capture. As technology developed, researchers realized that the position of the sun changes throughout the day. Because of this movement, a fixed solar panel cannot receive maximum sunlight all the time. To solve this problem, engineers introduced the concept of a solar tracking system, which allows the solar panel to move and follow the sun's direction. The earliest solar tracking systems were single-axis trackers. These trackers allowed the solar panel to rotate only in one direction, usually from east to west, following the daily movement of the sun. This system improved the efficiency of solar power generation compared to fixed panels. Later scientists developed the dual axis solar tracking system to further improve energy production. In this system, the solar panel can move in two directions: east–west and north–south. This enables the panel to follow the sun more accurately throughout the day and also adjust its position according to seasonal changes. Because of this capability, dual axis trackers can generate more electrical energy than single-axis or fixed systems. Initially, many solar trackers were designed using simple analog electronics. These systems used components such as Light Dependent Resistors (LDRs), operational amplifiers, relays and DC motors. The LDR sensors detect the direction of sunlight and the motors rotate the solar panel towards the direction of maximum light. These designs did not require any microcontroller or programming, making them simple and cost-effective. With the advancement of technology, microcontrollers and digital control systems were introduced to improve the accuracy and control of solar tracking systems. However, microcontroller-based systems are more complex and require programming knowledge. Even today, dual axis solar trackers without microcontrollers are widely used for educational purposes, research projects and small solar applications. These systems help students understand the basic working principle

of solar tracking using simple electronic components. The development of solar tracking technology has played an important role in increasing the efficiency of solar power systems. By allowing solar panels to follow the sun, these systems help in producing more electricity and promote the use of clean and renewable energy sources for a sustainable future.

## Tracking System Comparison

A Dual Axis Solar Tracker with a microcontroller uses a programmable control unit to process signals from the sensors and control the movement of the solar panel. In this system, the light intensity is detected by the Light Dependent Resistor sensors and the signals are sent to a Microcontroller such as Arduino or PIC. The microcontroller reads and compares the values from different sensors and then decides the direction in which the panel should move. After processing the data, it sends control signals to the L298N Motor Driver Module, which drives the DC Geared Motor to rotate the Solar Panel toward the direction of maximum sunlight.

## WORKING PRINCIPLE

The working principle of a Dual Axis Solar Tracker without a microcontroller is based on sensing the direction of maximum sunlight and automatically rotating the solar panel toward that direction. This is achieved using Light Dependent Resistors (LDRs), motor driver circuits and DC motors without any programmable controller. First, LDR sensors are placed around the solar panel to detect the intensity of sunlight from different directions. The resistance of an LDR changes according to the amount of light falling on it. When the sunlight is strong, the resistance decreases, and when the light is weak, the resistance increases. By comparing the light intensity on different LDRs, the system can determine the direction where sunlight is strongest. When there is a difference in light intensity between the LDRs, an electrical signal is generated. These signals are given to the L298N motor driver, which acts as the control unit of the system. The motor driver processes these signals and decides the direction in which the motors should rotate to align the solar panel with the sun. The DC motors connected to the motor driver move the solar panel in two directions. One motor controls the horizontal movement (east to west), while the other controls the vertical movement (north to south). This allows the panel to track the sun's position across the sky throughout the day, ensuring that the panel always faces the maximum sunlight. When the sunlight falls equally on the LDR sensors, it means the solar panel is already aligned with the sun. In this condition, the motors stop moving. This automatic adjustment helps the solar panel receive maximum solar energy, increasing the efficiency of the solar power system without the need for a microcontroller.

## HARDWARE COMPONENTS

This chapter describes the hardware components used in the Dual Axis Solar Tracker without Microcontroller. It explains the function and role of each component such as the solar panel, battery, LDR sensors, DC motors, L298N motor driver module and voltage regulator circuit. These components are selected based on simplicity, low cost and ease of implementation. The system operates by detecting the intensity of sunlight using LDR sensors and adjusting the position of the solar panel accordingly to receive maximum solar energy. The DC motors are controlled through the motor driver module, while the voltage regulator circuit ensures a stable power supply for proper operation. The integration of these components enables efficient solar tracking and improved power generation.

The Hardware Components are:

**SOLAR PANEL**



**Fig 1 Solar Panel**

**Specifications**

- Type: Polycrystalline Solar Panel
- Rated Power (Pmax): 5 Watts
- Nominal Voltage: 12 Volts
- Number of Cells: 36 cells
- Material: Polycrystalline Silicon
- Frame: Aluminium Frame

A solar panel is a device that converts sunlight into electrical energy using the photovoltaic effect. It is made up of many solar cells, usually made of silicon, which absorb sunlight and generate direct current (DC) electricity. When sunlight falls on the solar cells, electrons inside the semiconductor material become energized and start moving, producing an electric current. Solar panels are renewable energy devices that do not produce pollution and require very little maintenance. They are widely used in applications such as solar power plants, solar street lighting systems, water pumps, battery charging systems and solar tracking systems to generate clean and sustainable electricity.

**Role**

In this project, the solar panel is the main energy source.

- The panel absorbs sunlight, it converts sunlight into DC electrical energy.
- The electricity charges the battery.

- The battery powers the motor driver and DC motors used for tracking.
- Because of the dual-axis tracking mechanism, the panel always faces the sun, which increases the energy output.

**BATTERY**



**Fig 2 Battery**

**Specifications**

- Battery Type: Sealed Lead Acid (SLA)
- Rated Voltage: 12 V
- Capacity: 1.3 Ah
- Charging Voltage: 13.5 – 14.5 V
- Model: AT12-1.3

**Role**

In this project, the battery acts as the energy storage unit.

- The solar panel generates electricity from sunlight.
- The energy charges the 12V battery.
- The battery supplies power to the system.
- It powers: L298N Motor Driver Module, DC Motors for panel movement, sensor circuit.

**LDR (Light Dependent Resistor)**

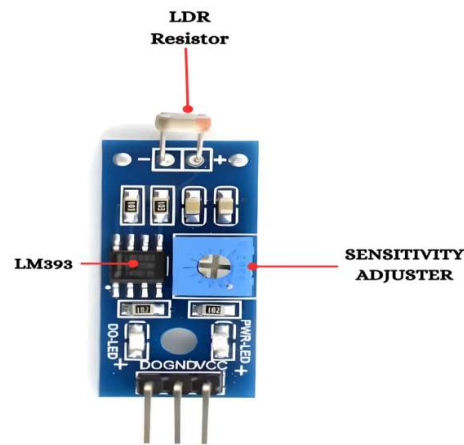

**Fig 3 LDR**

**Specifications**

- Operating Voltage: 3.3V – 5V DC
- Comparator IC: LM393
- Sensor Type: Light Dependent Resistor (LDR)
- Output Type: Digital Output (DO)
- Sensitivity Control: Adjustable potentiometer
- Detection Method: Light intensity detection
- Indicator LEDs: Power LED and Output LED

- Operating Current:  $\approx 15\text{--}20\text{ mA}$
- Pins:
  - VCC (Voltage Supply): Connected to 5V power supply. Provides power to the LDR module.
  - GND (Ground): Connected to the ground of the circuit. Completes the electrical circuit.
  - DO (Digital Output): Gives HIGH or LOW output depending on light intensity. This signal is used to control other components like motor driver

An LDR is a type of light sensor whose resistance changes according to the intensity of light falling on it. When the light intensity increases, the resistance of the LDR decreases and when the light intensity decreases, the resistance increases. LDRs are widely used in circuits that need to detect or measure light levels.

**Role**

- The LDRs detect the intensity of sunlight from different directions.
- They compare the light falling on each sensor.
- If one side receives more light, the system sends a signal to the motor.
- The motor then rotates the solar panel clockwise or anticlockwise and east–west.
- This movement helps the panel align with the direction of maximum sunlight.

**DC MOTOR**

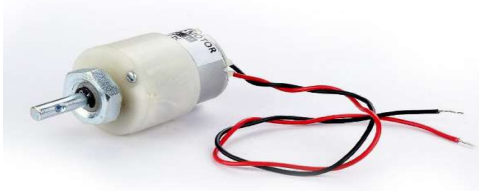

**Fig 4 DC motor**

**Specifications**

- Motor Type: DC Geared Motor
- Rated Speed: 10 RPM
- Operating Voltage: 6V – 12V DC
- Torque: High torque due to gearbox
- Direction of Rotation: Clockwise and Anticlockwise
- Power Source: DC supply

A 10 RPM DC geared motor is a low-speed electric motor that converts electrical energy into mechanical rotation. It contains a DC motor combined with a gearbox that reduces the speed and increases torque. These motors are widely used in robotics, automation systems and solar tracking projects where slow and controlled movement is required

**Role**

- DC motors are used to move and adjust the position of the solar panel so that it always faces the direction of maximum sunlight.
- Two DC motors are used in the system. One motor controls the horizontal movement (east–west

direction) of the solar panel, while the other motor controls the vertical movement (north–south or up–down direction).

- The motors receive control signals based on the light intensity detected by the LDR sensors.
- When the sunlight falls unevenly on the LDR sensors, the circuit activates the appropriate DC motor, causing the solar panel to rotate towards the direction of higher light intensity.
- Once all the LDR sensors receive equal light, the motors stop rotating.
- In this way, the DC motors help the solar panel continuously track the sun throughout the day, ensuring maximum solar energy absorption

**PIN DESCRIPTION**

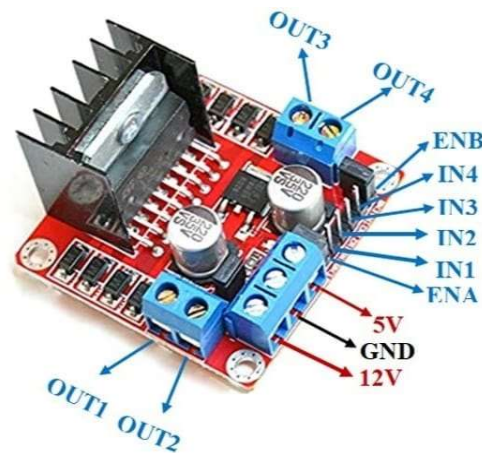

**fig.5 pin description of L298N**

- VCC (Motor Supply): This pin is used to provide the required power supply for driving the DC motors connected to the motor driver module.
- 5V (Logic Supply): This pin supplies power to the internal logic circuit of the motor driver.
- GND: This pin acts as the common ground connection for both the power supply and control circuit.
- ENA, ENB: These are the enable pins used to activate Motor A and Motor B. Speed control can be achieved by applying PWM signals to these pins.
- IN1, IN2: These pins are used to control the direction of rotation of Motor A by providing digital input signals.
- IN3, IN4: These pins are used to control the direction of rotation of Motor B.
- OUT1, OUT2 and OUT3, OUT4: These are output pins that are connected to the terminals of Motor A and Motor B respectively.

**Role**

- The L298N Motor Driver Module is used in the dual axis solar tracker to control the movement of the DC motors.
- It acts as an interface between the LDR sensor circuit and the motors.
- The signals from the LDR sensors are not strong enough to drive the motors directly, so the L298N

motor driver amplifies the signals and supplies the required current to the motors.

- It also controls the direction of rotation of the motors.
- In a dual axis solar tracker without a microcontroller, the L298N driver helps operate two DC motors, allowing the solar panel to move in both horizontal and vertical directions so that it continuously faces the direction of maximum sunlight.

### VOLTAGE REGULATOR

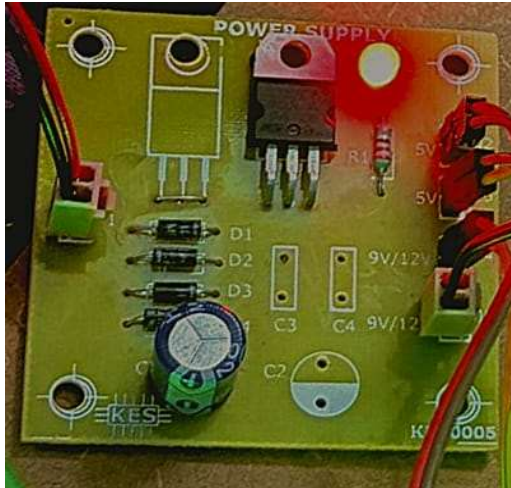

fig 6 Voltage Regulator

#### Specifications

- Type: Linear voltage regulator circuit
- Regulator IC: 7805 (5V output)
- Input Voltage: 9V – 12V DC
- Output Voltage: Regulated 5V DC
- Diodes: 1N4007 (4 diodes forming bridge rectifier)
- Capacitor: Electrolytic capacitor (~1000 $\mu$ F, 25V)
- Resistor: 220 $\Omega$  – 1k $\Omega$  (for LED)
- Indicator: Red LED for power indication

The voltage regulator circuit is designed to convert and maintain a constant DC output voltage from a varying input supply. In this circuit, four diodes are used to form a bridge rectifier, which converts AC input into DC (or provides polarity protection). The electrolytic capacitor filters the rectified output to reduce ripples and provide smooth DC voltage. The 7805-voltage regulator IC then regulates this voltage to a constant 5V output. A resistor and LED are connected to indicate the presence of power in the circuit. Input and output connections are provided through connectors on the PCB.

#### ROLE

- The voltage regulator circuit plays a crucial role in supplying a stable and constant 5V power to the system.
- It ensures that sensitive components such as LDR sensor modules and control circuitry receive proper voltage without fluctuations.

- This helps in preventing damage to components and ensures accurate sensing and smooth operation of the solar tracking system.

#### BLOCK DIAGRAM

In this system, the solar panel absorbs sunlight and generates electrical energy. This energy is stored in the 12V battery, which acts as the main power source for the system. The battery provides power to the power supply unit, which distributes the required voltage to the L298N motor driver and other components.

Four LDR sensors (LDR1, LDR2, LDR3 and LDR4) are connected to the L298 driver circuit. These LDRs detect the intensity of sunlight from different directions. The signals from the LDRs are used to control the movement of the motors.

The L298N motor driver acts as the control unit of the system. It receives input signals from the LDR sensors and power from the power supply. Based on the difference in light intensity detected by the LDRs, the driver controls the rotation of the motors. Two DC motors are connected to the L298N motor driver. One motor controls the horizontal movement (East–West direction) of the solar panel and the other motor controls the vertical movement (North–South direction). When one side receives more sunlight, the motor rotates the panel toward the brighter direction so that the solar panel always faces the sun.

#### DESCRIPTION OF EACH BLOCK

##### 1. Solar Panel

The Solar Panel is the main energy-generating component of the system. It consists of photovoltaic cells that convert sunlight directly into electrical energy using the photovoltaic effect. In this project, a 5W, 12V polycrystalline solar panel is used. When sunlight falls on the panel, it generates DC electricity. This electrical energy is used to charge the battery and power the components of the solar tracking system.

##### 2. Battery

The Sealed Lead Acid Battery stores the electrical energy generated by the solar panel. It acts as an energy storage device so that power can be supplied even when sunlight intensity decreases. The battery provides a stable DC supply to the LDR sensors, motor driver and DC motors, ensuring continuous operation of the solar tracking system.

##### 3. Power Supply

The power supply block regulates and distributes the electrical power to the electronic components of the system. It ensures that the required voltage is provided to the LDR sensors and the motor driver module. A stable power supply is important for proper sensor operation and smooth functioning of the DC motors.

##### 4. LDR Sensors (LDR1, LDR2, LDR3, LDR4)

The Light Dependent Resistor sensors are used to detect the intensity and direction of sunlight. Four

LDR sensors are placed around the solar panel in different directions. The resistance of an LDR decreases when light intensity increases and increases when light intensity decreases.

In this project:

LDR1 and LDR2 detect sunlight for east–west movement.

LDR3 and LDR4 detect sunlight for tilt or vertical movement.

When one LDR receives more light than the others, it produces a signal indicating the direction of maximum sunlight. This signal is then used to control the movement of the motors so that the solar panel can align with the sun.

**5. L298N Motor Driver**

The L298N Motor Driver Module is used to control the direction and movement of the DC motors. It is based on the L298N, which allows two DC motors to rotate in both clockwise and anticlockwise directions. The motor driver receives signals from the LDR sensors and controls the motors accordingly. Since motors require higher current than sensors can provide, the L298N driver acts as an interface between the sensor circuit and the motors.

**6. DC Motors**

The DC Geared Motor is used to rotate the solar panel toward the direction of maximum sunlight. Two DC motors are used in the project:

Motor 1: Controls the horizontal movement (East–West) of the solar panel.

Motor 2: Controls the vertical or tilt movement of the panel.

The motors rotate the panel clockwise or anticlockwise depending on the signals received from the motor driver. Because the motors operate at 10 RPM, the movement of the solar panel is slow and precise, which is suitable for solar tracking applications.

**CIRCUIT DESIGN**

**HARDWARE CIRCUIT DESIGN**

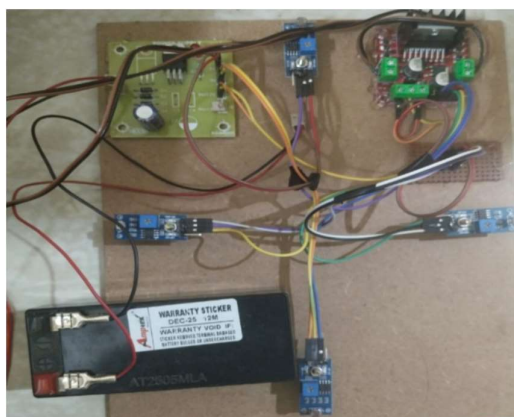

**Fig 7 Circuit design of Dual Axis Solar Tracker Without Microcontroller**

**EXPLANATION OF THE CIRCUIT**

The circuit diagram of the dual axis solar tracking system shows the interconnection of different hardware components used to detect sunlight and control the movement of the solar panel. The main components involved in the circuit include the Solar Panel, Light Dependent Resistor sensors, L298N Motor Driver Module, voltage regulator, capacitors, rectifier circuit and DC Motor units. Each component plays an important role in the operation of the solar tracking system. The power supply section provides the required voltage for the entire circuit. The input power is first passed through a bridge rectifier which converts the input into a stable DC supply. After rectification, capacitors are connected to filter the voltage and remove unwanted ripples from the output. These capacitors store electrical charge and release it when the voltage drops, thereby maintaining a smooth DC output. The filtered voltage is then given to a voltage regulator such as the 7805 Voltage Regulator, which provides a constant 5V output required for the sensor and control circuits. This regulated voltage ensures that the electronic components operate safely and reliably without voltage fluctuations. The light sensing section of the circuit uses multiple LDR sensors. These sensors are connected in a voltage divider configuration with resistors. When light falls on the LDR, its resistance changes depending on the intensity of the light. Higher light intensity decreases the resistance of the LDR, while lower light intensity increases it. Because of this property, the voltage across the LDR changes according to the amount of light received. These voltage variations act as signals that indicate the direction of maximum sunlight. The outputs from the LDR sensing circuit are connected to the motor driver control inputs. The motor driver used in the system is the L298N module, which acts as an interface between the low power sensor signals and the high-power DC motors. The module receives control signals at its input pins and accordingly drives the motors through its output terminals. The motor driver also includes internal H-bridge circuits that allow the motors to rotate in both clockwise and anticlockwise directions depending on the input signals. Two DC motors are connected to the output terminals of the motor driver module. One motor is responsible for horizontal movement of the solar panel, allowing it to rotate in the east–west direction to follow the movement of the sun throughout the day. The second motor controls the vertical movement or tilt of the solar panel so that it can adjust its angle according to the sun’s elevation. The motor driver provides sufficient current to operate the motors and ensures controlled movement of the panel. LED indicators are also connected in the circuit to show the status of the sensors and motor activation. When

a particular sensor detects higher light intensity, the corresponding LED may glow, indicating that the system is receiving light from that direction. This helps in visualizing the operation of the circuit during testing and demonstration.

When the system is powered on, the LDR sensors continuously monitor the light intensity from different directions. If one sensor detects higher light intensity compared to the others, a voltage difference is produced in the sensing circuit. This signal is then sent to the motor driver module, which activates the corresponding motor. The motor rotates the solar panel toward the direction of maximum sunlight. As the panel moves, the light falling on the sensors gradually becomes balanced. Once the light intensity on all sensors becomes nearly equal, the motors stop rotating. This ensures that the solar panel remains aligned with the direction of maximum sunlight.

Thus, through the combined operation of the sensing circuit, motor driver module and DC motors, the solar panel automatically adjusts its orientation to track the sun.

**5. Motor Control Section**

Two DC motors are used to rotate the solar panel in two directions:

Motor 1 – Horizontal Tracking

Controls East–West movement of the panel.

If East LDR receives more light → motor rotates panel toward East.

If West LDR receives more light → motor rotates panel toward West.

Motor 2 – Vertical Tracking

Controls tilt movement of the panel.

If top LDR receives more light → panel tilts upward.

If bottom LDR receives more light → panel tilts downward.

When the light intensity becomes equal on both sensors, the comparator output stops the motor.

**HARDWARE MODULE TESTING AND RESULTS**

**HARDWARE MODEL**



**fig 8 hardware model of Dual Axis Solar Tracker Without Microcontroller**

The hardware module of the dual-axis solar tracker consists of a solar panel, sensing unit, control circuit, motor driving system and power supply unit. The entire setup is designed to automatically adjust the position of the solar panel in both horizontal and vertical directions to maximize sunlight absorption.

At the core of the system is the solar panel, which converts sunlight into electrical energy using the principle of the photovoltaic effect. The panel is mounted on a mechanical frame connected to a DC motor, allowing it to rotate based on light intensity. The light sensing unit uses multiple LDRs placed at different positions around the panel. These LDRs continuously detect the intensity of sunlight from different directions. When sunlight falls unevenly, the resistance of each LDR changes, creating a voltage difference. This difference acts as the input signal for the control circuit.

The motor driving section consists of a DC motor connected to the panel through a shaft mechanism. Based on the output of the control circuit, the motor rotates either clockwise or anticlockwise to align the panel with the maximum light source. The motor is powered through switching element relays, ensuring proper current supply and direction control.

A battery is included in the system to store electrical energy and provide a stable power supply to the circuit. The power supply unit regulates voltage levels required for different components, ensuring safe operation. LEDs are used as indicators to show system status such as direction of movement or power availability.

Additionally, the entire hardware is mounted on a sturdy base with proper wiring connections to ensure reliability and ease of demonstration. The design eliminates the need for programming, making it simple, cost-effective.

**TESTING AND RESULTS:**

**Case 1: Light Falling Equally on All LDRs**



**fig 9 Light Falling Equally on All LDRs**

When equal light intensity falls on all the LDR sensors, their resistances remain nearly the same. Hence, no voltage difference is generated in the

control circuit. As a result, the DC motor remains in a stationary position and the solar panel does not move. This indicates that the panel is already aligned optimally with the light source.

#### Case 2: Light Intensity Higher on Top/Bottom



**fig 10 Light Intensity Higher on Bottom**

When light falls more on the upper or lower LDRs, a similar imbalance occurs in the vertical direction. The control circuit detects this difference and drives the motor accordingly. The panel tilts upward or downward until all LDRs receive equal light, ensuring proper vertical alignment.

#### RESULT

The dual-axis solar tracker was successfully designed and implemented using analog components without a microcontroller. The system effectively detects variations in light intensity using LDR sensors and automatically adjusts the position of the solar panel in both horizontal and vertical directions. During testing, the tracker consistently aligned the panel towards the direction of maximum light, ensuring optimal exposure. The DC motor responded accurately to control signals, and the system demonstrated stable and reliable operation under different lighting conditions, including low-light scenarios. The results confirm that the solar tracker improves the efficiency of energy generation compared to a fixed solar panel by maintaining continuous alignment with the light source. The project is simple, cost-effective and suitable for small-scale and educational applications.

#### CONCLUSION

This project demonstrates the practical implementation of an automatic solar tracking system using basic analog electronics. It highlights how light-dependent resistors and simple control circuits can be used to sense environmental changes and produce mechanical motion without the need for programming. Through this work, we understand the importance of proper solar panel orientation in improving energy utilization. The project also provides insight into sensor-based control systems, motor driving techniques and real-time response to external conditions. In addition, the design shows that efficient and intelligent systems can be built using low-cost components, making it suitable for educational learning and small-scale applications. The concept can be further enhanced by integrating advanced control methods for higher accuracy and efficiency.

#### REFERENCES

1. Reza Sadeghi, Mohammad Rezaei, Ali Karimi, and Hossein Mohammadi, "A Comprehensive Review and Comparative Analysis of Solar Tracking Systems," 2025.
2. Priyam Bhattacharya, Arjun Sen, Rahul Verma, and Neha Sharma, "Design and Analysis of Dual-Axis Solar Tracking System for Enhanced Energy Capture," 2025.
3. Prajwal D, Karthik R., Sandeep Kumar, and Anil Kumar, "Design and Implementation of Dual-Axis Solar Tracker for Improved Photovoltaic Efficiency," 2024.
4. S. S. Jaafar, M. N. Abdullah, A. H. Rahman, and N. F. Ismail, "Comparative Performance Evaluation of Dual-Axis Solar Tracking Systems," 2024.
5. Focus on dual-axis solar tracking systems for maximizing energy efficiency.
6. Comparative studies highlight the performance differences between various tracking designs.
7. Research emphasizes design improvements for enhanced photovoltaic output.
8. Implementation strategies include both mechanical and automated tracking solutions.
9. Reviews and analyses provide a consolidated understanding of solar tracking advancements.
10. The references collectively cover design, evaluation, and performance enhancement of solar trackers.